

The versatile Nopon Clean formic-acid cleaning system is simple to use and ensures fine and medium bubble diffusers are kept clean and close to peak performance. During use the slits/pores in the active surface of diffusers may become clogged and consequently oxygen transfer suffers. The rate of degradation will depend largely on the chemical composition of the wastewater however even if some pores are still open the back pressure on the compressor rises and the energy consumption increases significantly. Cleaning clogged diffusers improves the oxygen transfer and reduces back pressure.

As the cost of cleaning is low with the Nopon Clean it is feasible to clean the diffusers at shorter intervals, thereby further reducing the running cost of the aeration system. Regular cleaning has also been shown to increase the economical life of the membranes.

Formic acid

The cleaning agent used is 80-90 % formic acid, which is an ideal chemical for this purpose. Formic acid is sufficiently strong to dissolve most deposits in the diffuser pores and membrane slits. At the same time it is safe to use, easy to dispense and does not interfere with the biological process.



Installation example

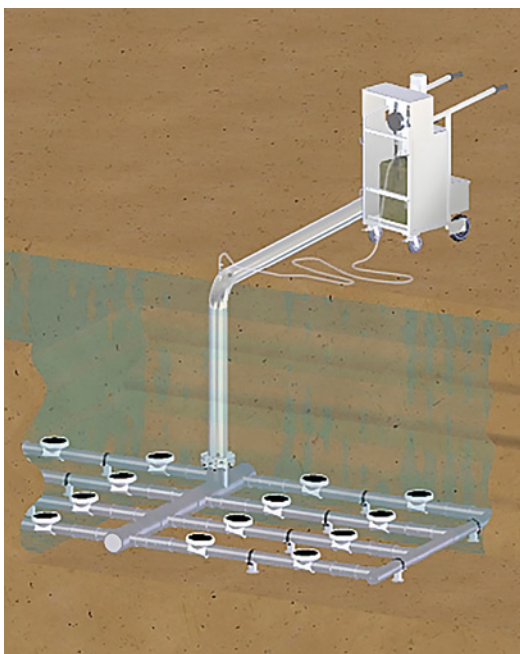

Operation

During cleaning there is no need to drain the aeration basin or to remove the diffusers. As a result, the treatment process remains unaffected by the cleaning operation.

The equipment consists of a pump unit, a distribution manifold, a control box, valves and nozzles. The pump unit draws formic acid from a container and supplies it via the distribution manifold to the nozzles, which spray it into the droplegs in a fine mist. From there the acid is carried by the air to the diffusers. Pump operation times are set with the control box. Aeration groups are cleaned one by one. The mobile equipment is mounted on a push-cart for easy transportation.

Installation

The nozzle unit is welded to the dropleg and Nopon Cleans' feeding hose is attached to the nozzle unit with a quick-coupling.



Main components and materials

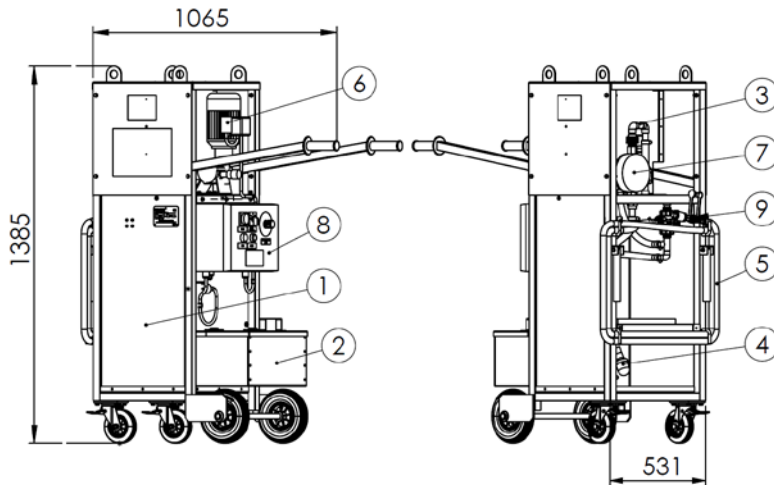

	Description	(Main)Material
1	Push-cart	Aluminum
2	Box for accessories	Aluminum
3	Manifold parts	U-PVC
4	Suction strainer	U-PVC
5	Hoses	PVC (fibre-reinforced)
6	Motor	Painted steel
7	Pump	Painted steel
8	Control box	Plastic casing
9	Nozzle unit	Stainless steel

Also included in the delivery is a set of protective gear: rubber gloves and safety goggles.

Technical specification

Membrane pump	0-108 l/h ¹ , 8 bar, 230 V AC, 50 Hz G $\frac{1}{2}$ " connections
Control box	Plastic housing, opening lid - contactor - motor overheat protection - time relay 0,02 s - 300 h - start switch (manual or automatic function) - reset button - emergency stop switch
Suction strainer	ø 20 mm hose connection
Relief valve	6 bar (set value) G $\frac{1}{2}$ " connections
3-way valve	ø 20 mm connection
Feeding hose	ø 19/25 mm, length 5 m
Nozzle unit	1,2 l/min at 2 bar (with water)

¹⁾ Capacity value is subject to change due to operational pressure, dosed liquid, viscosity and installation asset.